

# Columbia

**PAKONA**  
ENGINEERING PVT. LTD.

The Model FLm10 floor level palletizer provides a low cost reliable solution to your material handling needs. This floor level automatic palletizer is ideal for lower speed production line applications with speeds of 10 or more cases per minute depending on case size and pallet pattern. Like all heavy-duty Columbia Machine palletizers, it has a reliable welded frame that is "built to last" and is EASY TO OPERATE.

## Model FLm10



### FEATURES

- Small footprint - uses less than 60 square feet of floor space
- Compact size - fits through an 8' x 8' doorway
- Stacks cases, trays, bundles and more
- Local support for parts and service

- Easy-to-operate, pre-programmed with common patterns
- Pallet positions for manually placed pallets
- Reliable - Columbia has over 70 years in the industry
- FLm 10 manufactured in India

### OPTIONS

- Sheet dispenser
- Soft product turning
- Pallet dispenser
- Stainless/Washdown



# Model FLm10

Palletizer Footprint (Many layout options available)

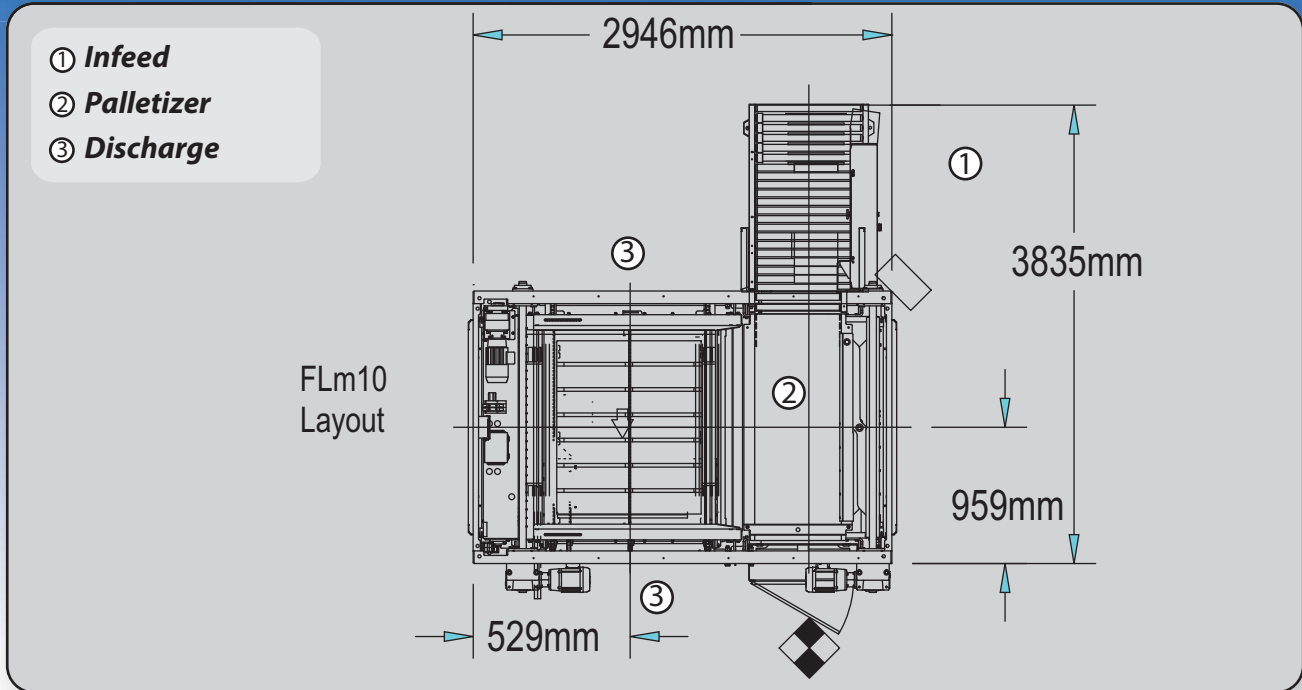

There are several reasons for choosing to palletize your packaging line automatically. First, palletizers stack a better quality load. Product damage caused by irregular loads is now part of the payback analysis to justify a palletizer. Secondly, palletized loads help save space as they are able to be stacked for onsite storage or shipping requirements.



Hand stacked load



Machine palletized loads



**Manufacturing Facility:**

333, G.I.D.C., MAKARPURA  
VADODARA, 390010 INDIA  
Website: [www.columbia-pakona.com](http://www.columbia-pakona.com)



Sales Representation

**Corporate Office:**

22-D, Wadia Charities Building,  
S A Brelvi Road, Fort, Mumbai 400 023, INDIA  
Tel.: (91-22) 22854138, 22826751  
Fax: (91-22) 22876171  
Email: [columbiachines@pakona.com](mailto:columbiachines@pakona.com)  
Website: [www.pakona.com](http://www.pakona.com)